

*Dans l'espace réponse réservé à chaque partie  
le candidat identifiera impérativement clairement le numéro de la question à laquelle il répond.*

**I - INTERÊT DE LA SOLUTION FUNITEL (1 page) [1 : g sous un vent constant – 2 : Amplitude sous une rafale de vent - 3 : Variation des composantes verticales]**

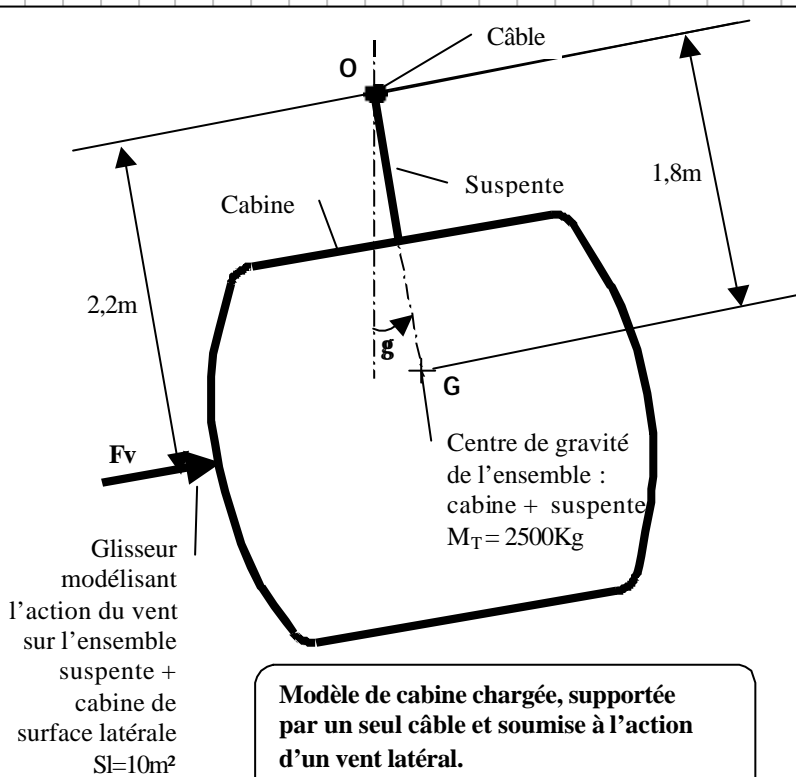

<b>g</b>	5	10	15	20	25	30	35
<b>sin(g)</b>	0.09	0.17	0.26	0.34	0.42	0.5	0.57
<b>cos(g)</b>	0.99	0.98	0.97	0.94	0.91	0.87	0.82
<b>tan(g)</b>	0.087	0.18	0.27	0.36	0.47	0.58	0.70

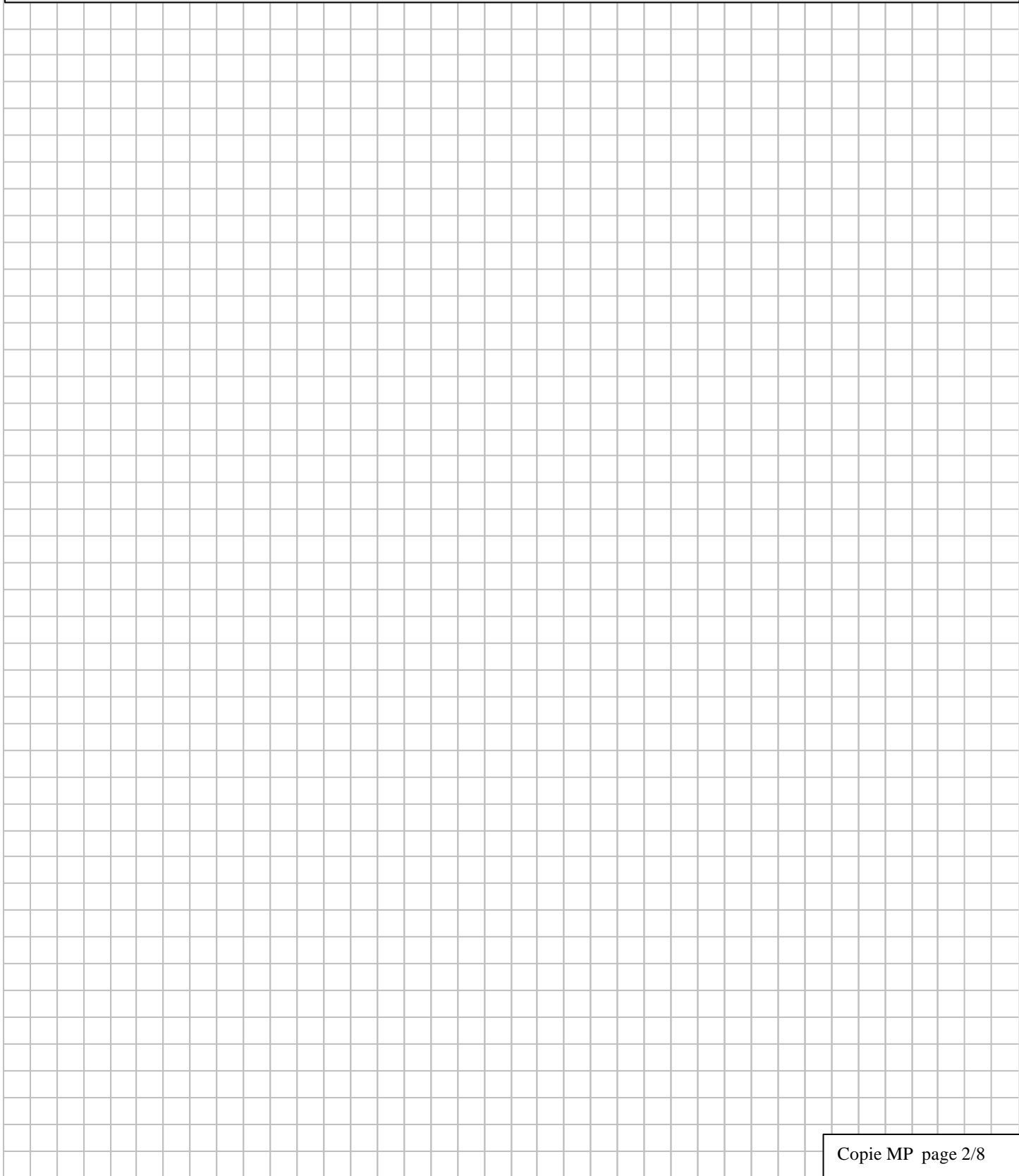

III ETUDE DE LA SORTIE DE GARE D'UNE CABINE (1 page)  
à x = 0.90 – 10 : Dessin courroies – 11 : valeur de K]

[8 : Durée et longueur d'accélération – 9 : Vitesse

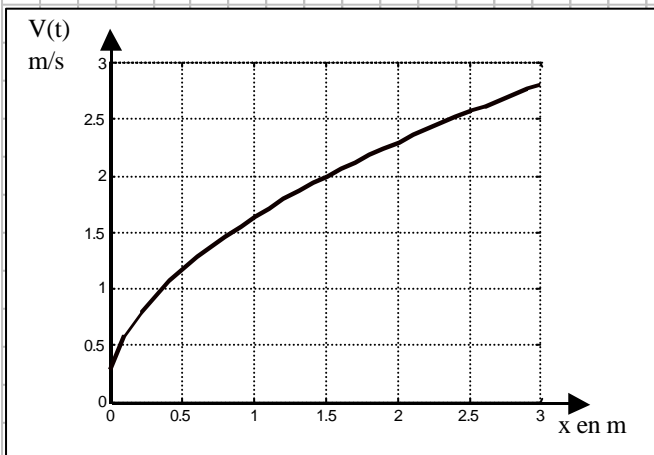

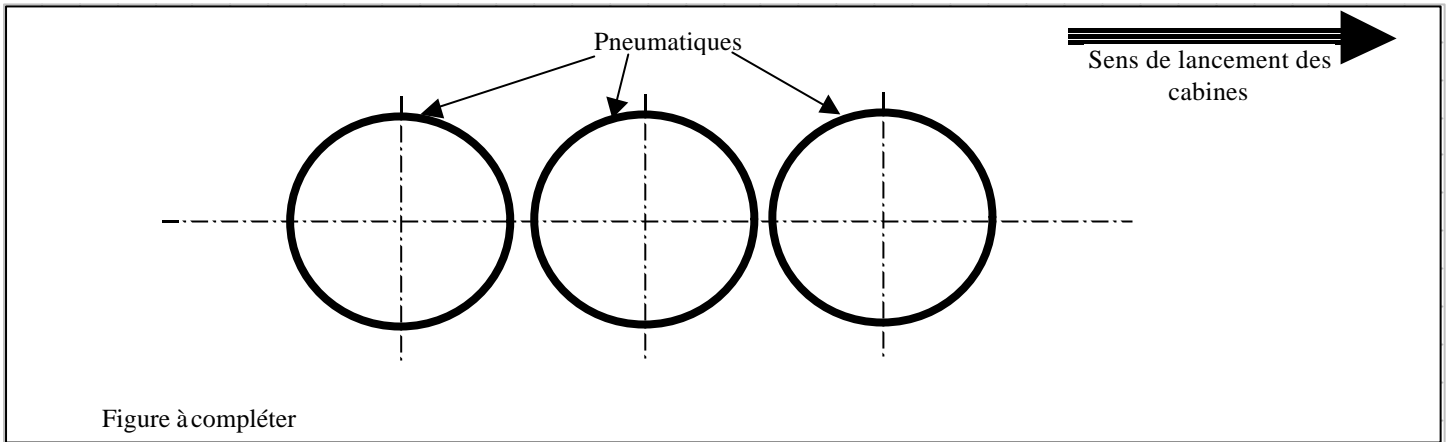

**IV GESTION DU FLUX DE CABINES DANS LES GARES (1 page)**  
**13 : Commande de ME (PC2)]**

[12 : Commande PC1 –

Secteurs	A	B	C	D	E	F
Etat de départ : $t = 0$	X			X		X
Etat à : $t = 1*DT$						
Etat à : $t = 2*DT$						

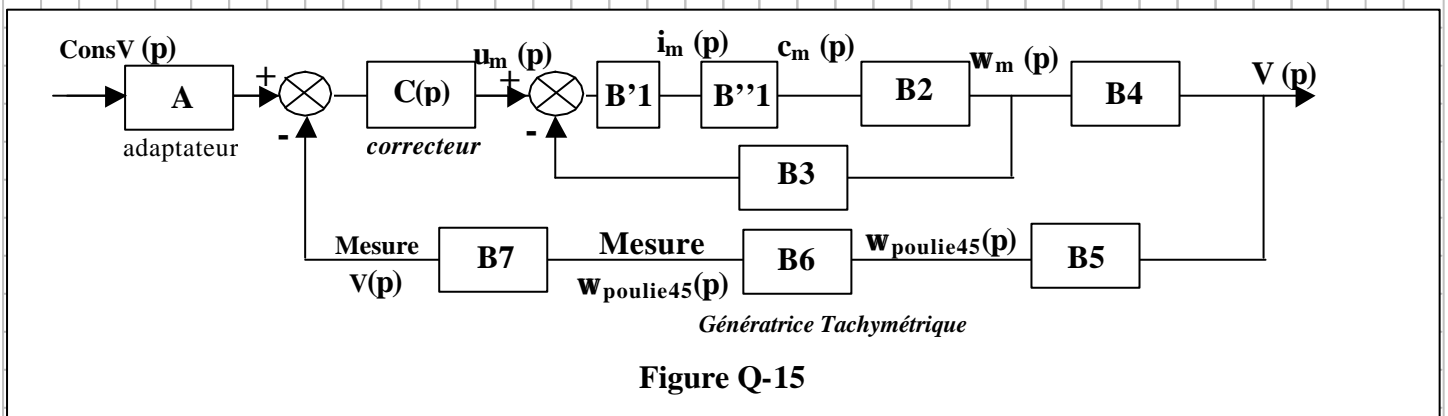

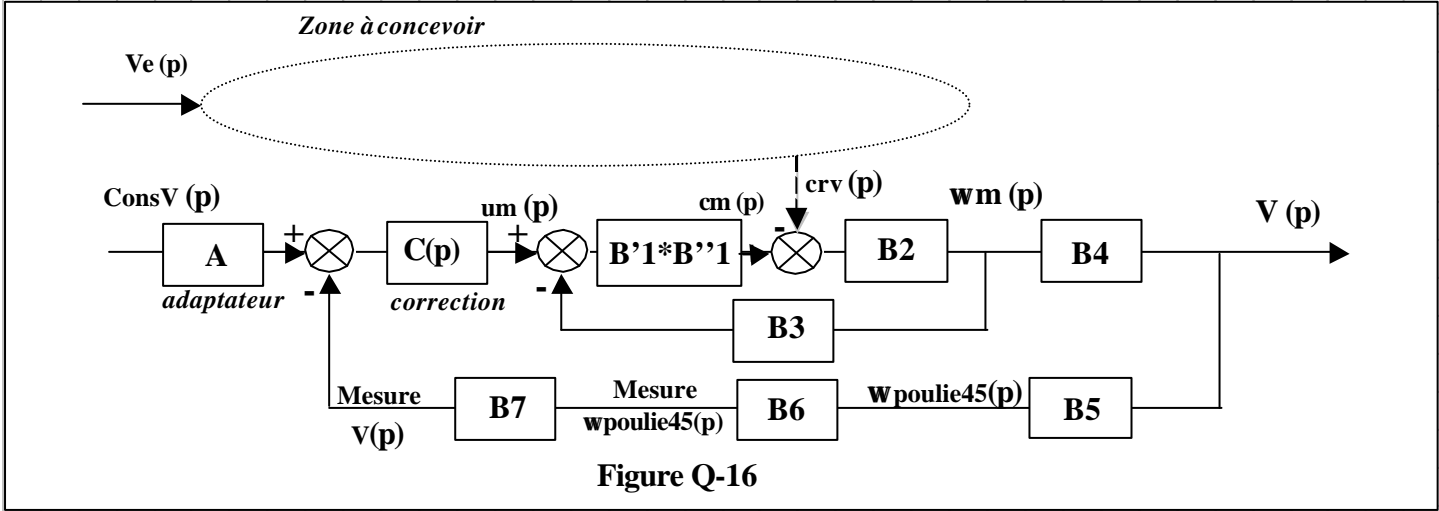
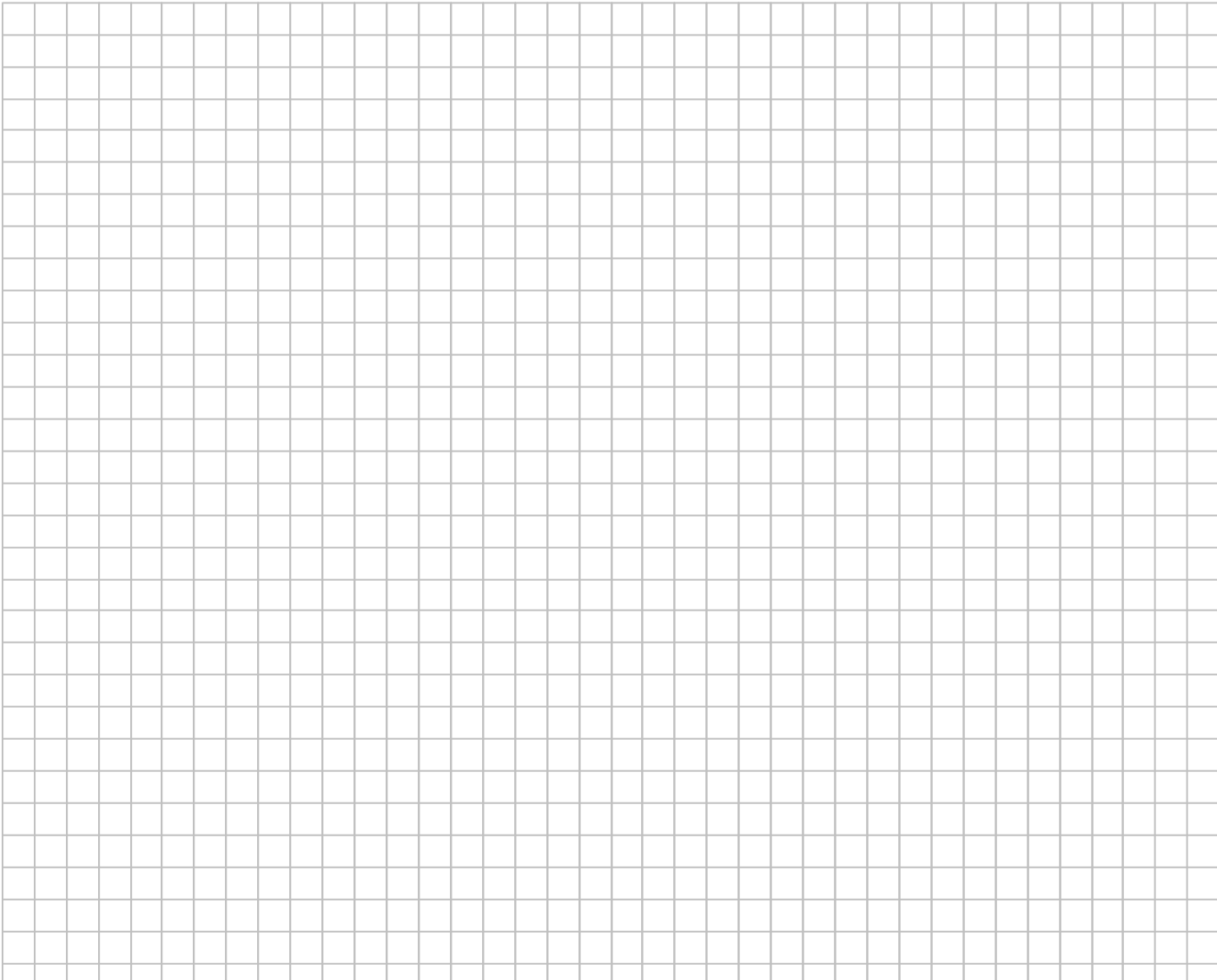
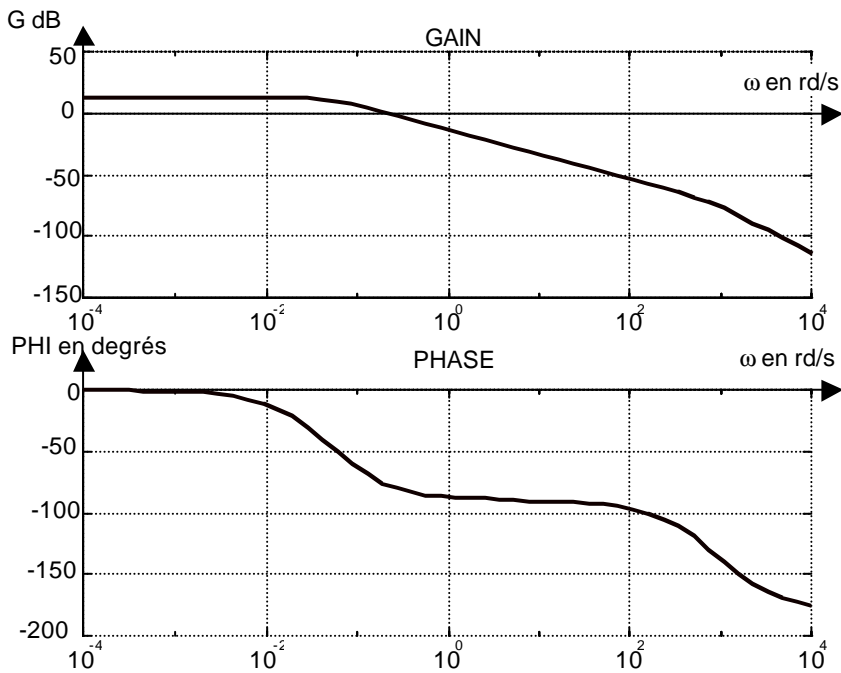
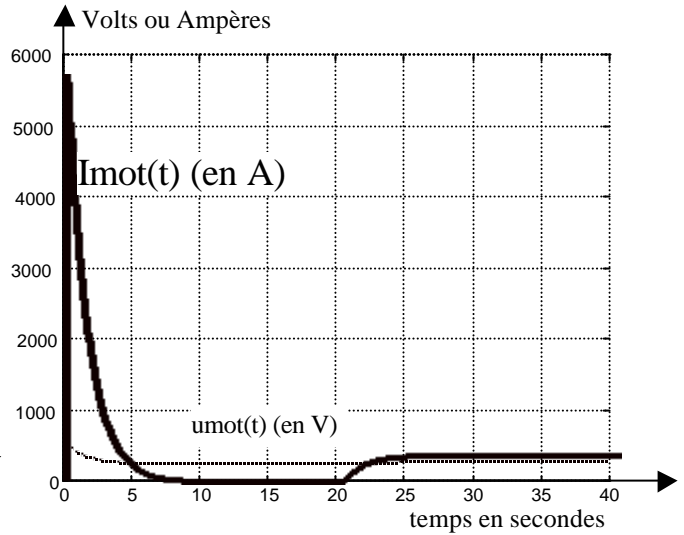
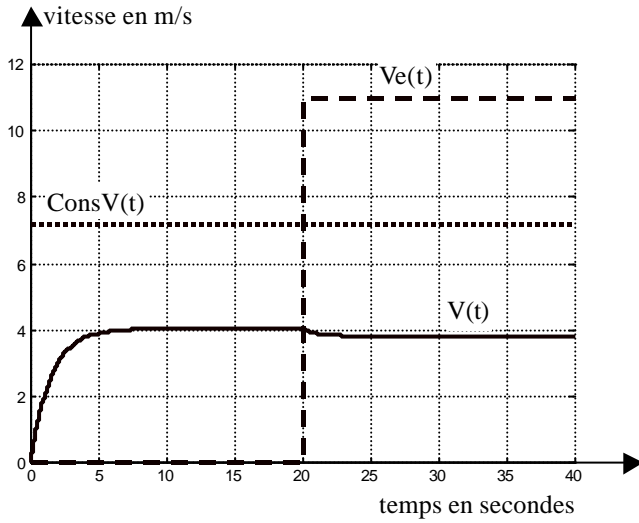

Figure Q-16

**Q 17** — **C1(p) = KP = 300**



KP	300	>300	< 300
Précision			
Marges de stab.			
Imax			
Umax			

Conclusions par rapport au cahier des charges

Expression de Umot

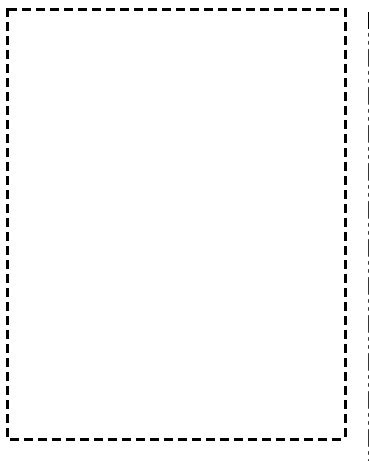

Zone d'implantation  
des poulies avals

